

MANUFACTURERS

"AFC" LOGO
 .025 MAX
 RAISED OR INDENTED

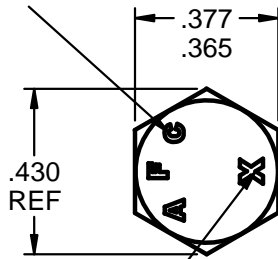

"X" ALLOY STEEL
 GRADE MARK

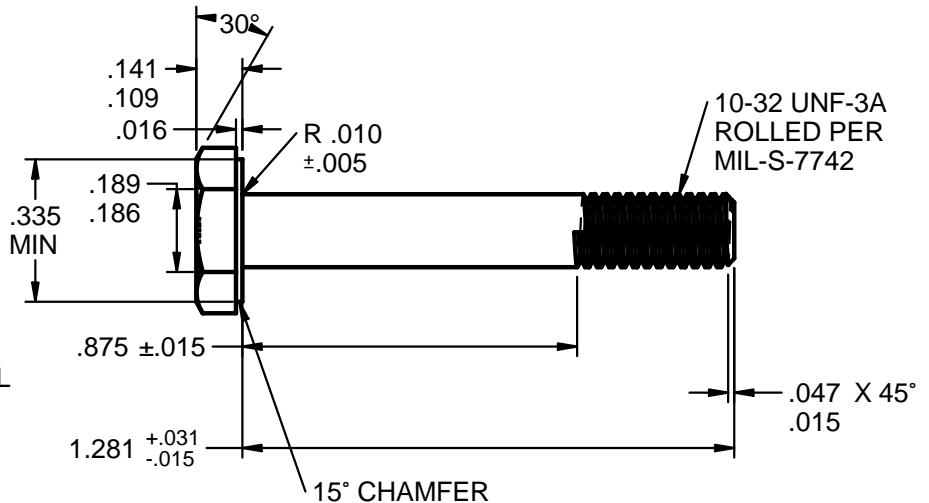

SCALE: 2X

DESIGN NOTES: AN3-12A AIRFRAME BOLT

1. LENGTH 1-9/32" (1.281"), GRIP 7/8" (.875"), THREAD 10-32 UNF-3A.
2. PROCUREMENT SPECIFICATION NASM6812.
3. PREFERRED MATERIAL ALLOY STEEL PER PROCUREMENT SPECIFICATION.
 UNS G40370 AMS6300 DFAR EXEMPT
 UNS G87400 AMS6322 DFAR APPLIES
 UNS G41400 AMS6382 DFAR APPLIES
 UNS G41300 AMS-S-6758 DFAR APPLIES
4. HEAT TREAT AMS-2759 HRC 26-32.
5. FINISH CADMIUM PLATED PER AMS-QQ-P-416, TYPE 2 (YELLOW), CLASS 2.
6. THREADS 10-32 UNF-3A ROLLED PROCESS PER MIL-S-7742.
7. TENSILE 2,210 LBS. [9,830 N] MIN.
8. YIELD 1,690 LBS. [7,517 N] MIN.
9. SINGLE SHEAR 2,125 LBS. [9,415 N] MIN. SHORT LENGTH N/A.

EXAMPLE PART NUMBER

AFC 3-12 C2 - CADMIUM TYPE 2 YELLOW PLATING
 AFC 3-12 C1 - CADMIUM TYPE 1 PLAIN WHITE PLATING
 AFC 3-12 TDC - THERMAL DIFFUSION COATED ASTM A1059

↑ FINISH
 ↑ LENGTH 1.281"
 ↑ BODY SIZE & THREAD .190-32 UNF-3A
 ↑ MANUFACTURER AIRFASCO



ACTUAL SIZE

UNCONTROLLED

CONFORMS TO: NASM3 THRU NASM20
 PART NUMBER: AN3-12A

DIMENSIONS ARE IN INCHES AND TOLERANCES ARE AS SHOWN BELOW. DIMENSIONAL TOLERANCES AND SYMBOLS PER ANSI Y14.5M-1982	PROPRIETARY PARTS SHOWN IN THIS DRAWING ARE THE SUBJECT OF ISSUED UNITED STATES AND FOREIGN PATENTS AND PATENTS PENDING. UNAUTHORIZED REPRODUCTION AND/OR DISTRIBUTION OF THIS DRAWING IS STRICTLY PROHIBITED.		AIRFASCO.com 2655 HARRISON AVE SW, CANTON, OHIO 44706 USA	
	APPROVALS DRAWN C.D. CHECKED T.W. ENG APPR B.E. MGR APPR D.D.		DATE 6/10/13 6/10/13 6/10/13	
ANGLES ±5° .XX ±.03" .XXX ±.010" .XXXX ±.001"	PART NUMBER: AN3-12A_AFC3-12C2		REV	
SCALE: 2X		MATERIAL: 4037 / 8740 OR AS NOTED		EST. WEIGHT: .013 / EACH LBS. [6.0 g]
DRAWING NUMBER: AN3-12A_AFC3-12C2		SHEET 1 OF 1		