

MANUFACTURERS  
"AFC" LOGO  
.025 MAX  
RAISED OR INDENTED

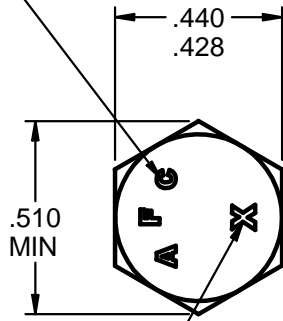

"X" ALLOY STEEL  
GRADE MARK

SCALE: 2X

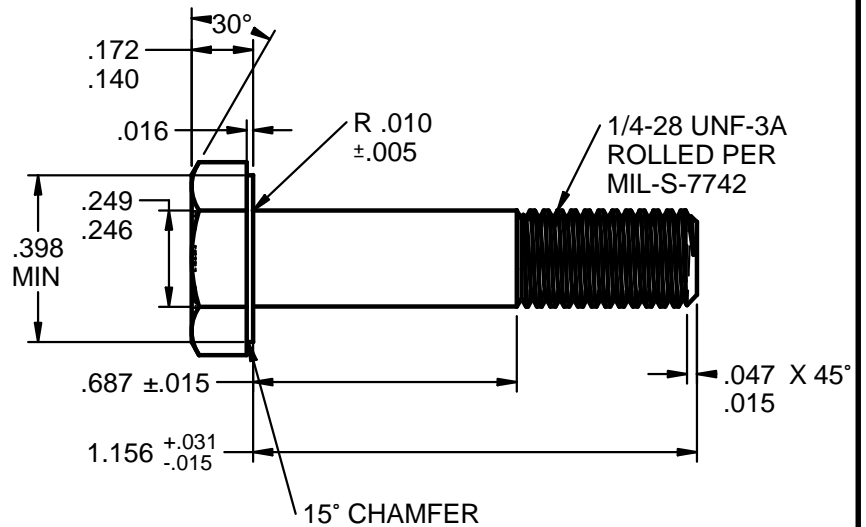

**DESIGN NOTES: AN4-11A AIRFRAME BOLT**

1. LENGTH 1-5/32" (1.156"), GRIP 11/16" (.687"), THREAD 1/4-28 UNF-3A.
2. PROCUREMENT SPECIFICATION NASM6812.
3. PREFERRED MATERIAL ALLOY STEEL PER PROCUREMENT SPECIFICATION.  
UNS G40370 AMS6300 DFAR EXEMPT  
UNS G87400 AMS6322 DFAR APPLIES  
UNS G41400 AMS6382 DFAR APPLIES  
UNS G41300 AMS-S-6758 DFAR APPLIES
4. HEAT TREAT AMS-2759 HRC 26-32.
5. FINISH CADMIUM PLATED PER AMS-QQ-P-416, TYPE 2 (YELLOW), CLASS 2.
6. THREADS 1/4-28 UNF-3A ROLLED PROCESS PER MIL-S-7742.
7. TENSILE 4,080 LBS. [18,148 N] MIN.
8. YIELD 3,130 LBS. [13,922 N] MIN.
9. SINGLE SHEAR 3,680 LBS. [16,369 N] MIN. SHORT LENGTH N/A.

EXAMPLE PART NUMBER

AFC 4-11 C2 - CADMIUM TYPE 2 YELLOW PLATING  
 AFC 4-11 C1 - CADMIUM TYPE 1 PLAIN WHITE PLATING  
 AFC 4-11 TDC - THERMAL DIFFUSION COATED ASTM A1059

↑ FINISH  
 ↑ LENGTH 1.156"  
 ↑ BODY SIZE & THREAD 0.25-28 UNF-3A  
 ↑ MANUFACTURER AIRFASCO



ACTUAL SIZE

**UNCONTROLLED**

CONFORMS TO: NASM3 THRU NASM20  
PART NUMBER: AN4-11A

DIMENSIONS ARE IN INCHES AND TOLERANCES ARE AS SHOWN BELOW. DIMENSIONAL TOLERANCES AND SYMBOLS PER ANSI Y14.5M-1982	PROPRIETARY PARTS SHOWN IN THIS DRAWING ARE THE SUBJECT OF ISSUED UNITED STATES AND FOREIGN PATENTS AND PATENTS PENDING. UNAUTHORIZED REPRODUCTION AND/OR DISTRIBUTION OF THIS DRAWING IS STRICTLY PROHIBITED.		<b>AIRFASCO.com</b> 2655 HARRISON AVE SW, CANTON, OHIO 44706 USA	
	APPROVALS DRAWN C.D.      DATE 6/10/13 CHECKED T.W.      6/10/13 ENG APPR B.E.      6/10/13 MGR APPR D.D.      6/10/13		PART NUMBER: AN4-11A_AFC4-IIC2      REV	
ANGLES ±5° .XX ±.03" .XXX ±.010" .XXXX ±.001"	SIZE A MATERIAL: 4037 / 8740 OR AS NOTED		EST. WEIGHT: .021/ EACH LBS. [9.6 g]	
SCALE: 2X		DRAWING NUMBER: AN4-11A_AFC4-IIC2		SHEET 1 OF 1