

**MANUFACTURERS**

"AFC" LOGO

.025 MAX

RAISED OR INDENTED

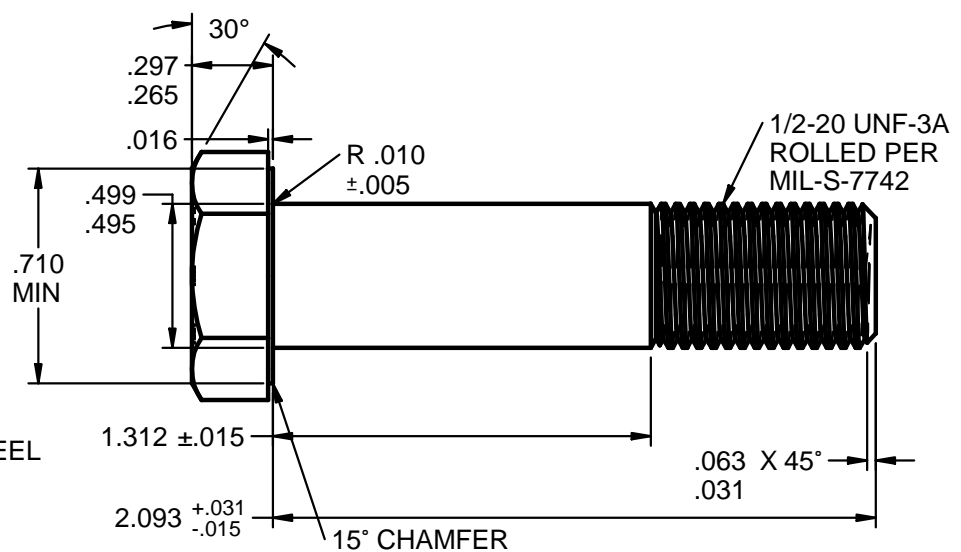
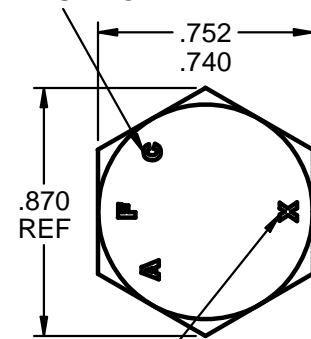

SCALE: 1.5X

**DESIGN NOTES: AN8-20A AIRFRAME BOLT**

1. LENGTH 2-3/32" (2.093"), GRIP 1-5/16" (1.312"), THREAD 1/2-20 UNF-3A.
2. PROCUREMENT SPECIFICATION NASM6812.
3. MATERIAL ALLOY STEEL PER PROCUREMENT SPECIFICATION.  
 UNS G40370 AMS6300 DFAR EXEMPT  
 UNS G87400 AMS6322 DFAR APPLIES  
 UNS G41400 AMS6382 DFAR APPLIES  
 UNS G41300 AMS-S-6758 DFAR APPLIES
4. HEAT TREAT AMS-2759 HRC 26-32.
5. FINISH CADMIUM PLATED PER AMS-QQ-P-416, TYPE 2 (YELLOW), CLASS 2.
6. THREADS 1/2-20 UNF-3A ROLLED PROCESS PER MIL-S-7742.
7. TENSILE 18,500 LBS. [82,292 N] MIN.
8. YIELD 14,190 LBS. [63,120 N] MIN.
9. SINGLE SHEAR 14,700 LBS. [65,388 N] MIN. SHORT LENGTH N/A.

EXAMPLE PART NUMBER

AFC 8-20 C2 CADMIUM TYPE 2 YELLOW PLATING  
 AFC 8-20 C1 CADMIUM TYPE 1 PLAIN WHITE PLATING  
 AFC 8-20 TDC THERMAL DIFFUSION COATED ASTM A1059

↑ FINISH  
 ↑ LENGTH 2.093"  
 ↑ BODY SIZE & THREAD 0.5-20 UNF-3A  
 ↑ MANUFACTURER AIRFASCO



ACTUAL SIZE

**UNCONTROLLED**

CONFORMS TO: NASM3 THRU NASM20  
 PART NUMBER: AN8-20A

DIMENSIONS ARE IN INCHES AND TOLERANCES ARE AS SHOWN BELOW. DIMENSIONAL TOLERANCES AND SYMBOLS PER ANSI Y14.5M-1982	PROPRIETARY PARTS SHOWN IN THIS DRAWING ARE THE SUBJECT OF ISSUED UNITED STATES AND FOREIGN PATENTS AND PATENTS PENDING. UNAUTHORIZED REPRODUCTION AND/OR DISTRIBUTION OF THIS DRAWING IS STRICTLY PROHIBITED.		<b>AIRFASCO.com</b> 2655 HARRISON AVE SW, CANTON, OHIO 44706 USA	
	APPROVALS DRAWN M.B. DATE 6/5/2014 CHECKED T.W. DATE 6/5/2014 ENG APPR B.E. DATE 6/5/2014 MGR APPR D.D. DATE 6/5/2014		PART NUMBER: AN8-20A_AFC8-20C2 SIZE A MATERIAL: 4037 / 8740 OR AS NOTED EST. WEIGHT: .145 / EACH LBS. [66.0 g]	
ANGLES ±5° .XX ±.03" .XXX ±.010" .XXXX ±.001"	SCALE: 1.5X DRAWING NUMBER: AN8-20A_AFC8-20C2		SHEET 1 OF 1	